

**MAKE YOUR  
TRADE SHOW  
A SUCCESS!**

Faites votre  
**EXPOSITION  
COMMERCIALE  
un SUCCÈS!**

Display systems solutions  
Solutions de systèmes d'affichages

# Banner *Stands* (Retractable)

**CB** = Carry Bag included

Choose from a wide choice of lightweight, easy-to-use, portable roller-retractable and interlocking pole banner stands. Each system has its own unique features and benefits, from the cost efficient Pacific to the stylish Merlin. Products are manufactured to the highest standards and stocked in quantity for immediate delivery.



## **CB** Merlin

- Interchangeable 31.5" wide image cassette
- Changing the image is easy for a fast set up every time
- Additional cassette cartridges available for all new graphics
- Textured silver finish with black end caps



## **CB** Excalibur 32, 36, 48

- 3 standard graphic widths 31.5" 35.5" & 47.25"
- Single or double sided with retractable roller
- Extremely stylish and reliable
- Textured black finish



## **CB** Pacific

- 31.5", 36", 39.25" wide banner stand
- Interlocking pole design
- Swiveling foot for stability
- Matte silver finish
- Value plus features



## **CB** Orient

- 31.5" & 39.25" wide banner stand
- Interlocking pole
- Sophisticated look and feel
- Simple to set up quickly
- Matte silver finish
- Value plus features

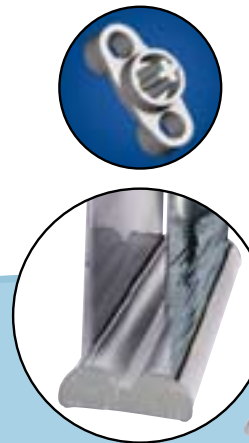

## **CB** Orient 2

- 31.5" wide banner stand
- Double sided display
- Simple to set up quickly
- Matte silver finish
- Value plus features
- Interlocking pole design





**CB** **Contender**

- 29.5" wide graphics
- Dependable strong construction
- The ultimate in portability for stands
- High shine silver or silk black finish

**CB** **Contender Plus**

- Stylish and practical 36" wide
- Perfect for larger presentations
- High shine silver or silk black finish



**CB** **Stretch**

- 24" & 31.5" wide single graphic
- Telescopic pole design
- Twist out foot for stability
- Simple to set up quickly
- Black finish



**CB** **Discovery**

- 31.5" wide single graphic
- Interlocking pole design
- Simple to set up quickly
- Black finish



**Lumina 2**

- Comes complete with 35 watt bulb
- Will take 35 or 50 watt replacement bulbs

\* Not for use with I-Banner, Metro, Contender, Challenger, Double Sided Dash.



**2 Bulb Replacement Pack**  
• 2- 35 watt or 50 watt halogen bulbs in a protective case



**CB** **Barracuda**

- 31.5" or 36" wide, strong, stylish banner
- Interlocking pole design
- Ideal for simple displays or exhibitions
- Versatile and economical
- Textured black or silver finish

**CB** **Challenger**

- 29.5" wide double sided
- Roller retractable
- Remarkably easy to use
- High shine silver & silk black finish

# Banner *Stands* ( Non-Retractable )

Choose from a wide choice of lightweight, easy-to-use, portable roller-retractable and interlocking pole banner stands. Each system has it's own unique features and benefits, from super cost efficient I-Banner to the stylish Dash. Products are manufactured to the highest standards and stocked in quantity for immediate delivery.

**CB** = Carry Bag included



## Dash TELESCOPIC **CB**

- 36" wide banner stand
- Lightweight, fast assembly
- Silver finish



## Mini Dash TELESCOPIC **CB**

- 31.5" wide banner stand
- Lightweight, fast assembly
- Maximum graphic height 79"
- Silver finish

Fabric Brochure  
EXTENSION

13"

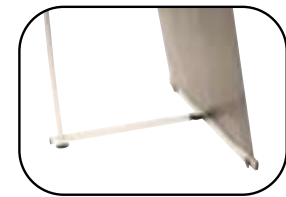

## Lightning SPRING BACK **CB**

- 31.5" wide banner stand
- Interlocking pole design
- Unique slim-line design works well in any environment
- Silver finish

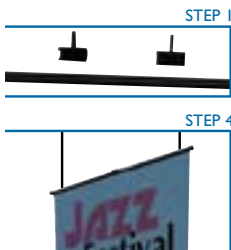

Converts to a hanging banner with clips



## I-Banner SPRING BACK **CB**

- 3 sizes available 24", 27.5", 36" wide
- Provides two heights in one
- Low cost lightweight system
- Black finish



## Mini Vortex

- Graphic size is 12" w X 16.5" h
- Shown on EFEX counter
- Ideal for retail / POP
- Mini tabletop banner stand

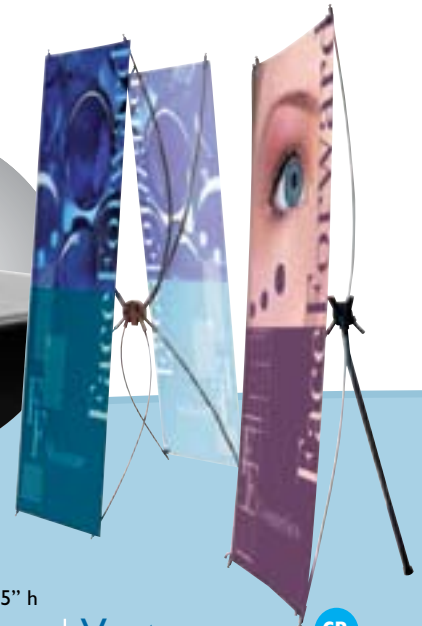

## Vortex X-FRAME **CB**

- 27.5" wide banner stand
- Designed for graphics with "eyelet" grommet corners
- Comes complete with extra arms to use as a double sided banner.
- Black finish



CB

### Uno TELESCOPIC

- Quick and elegant 31.5" w system
- Aluminum foot provides stability
- Simple to use telescopic banner
- Textured black finish



CB

### Uno Plus TELESCOPIC

- Same simple "Uno" design with a wider 36" w panel
- Great display to add a spot light



CB

### Uno Monster TELESCOPIC

- Same simple "Uno" design with a wider 47.5" w panel



CB

### Uno Double TELESCOPIC

- Same simple "Uno" design with two 31.5" w panels
- Great display for adding a spot light

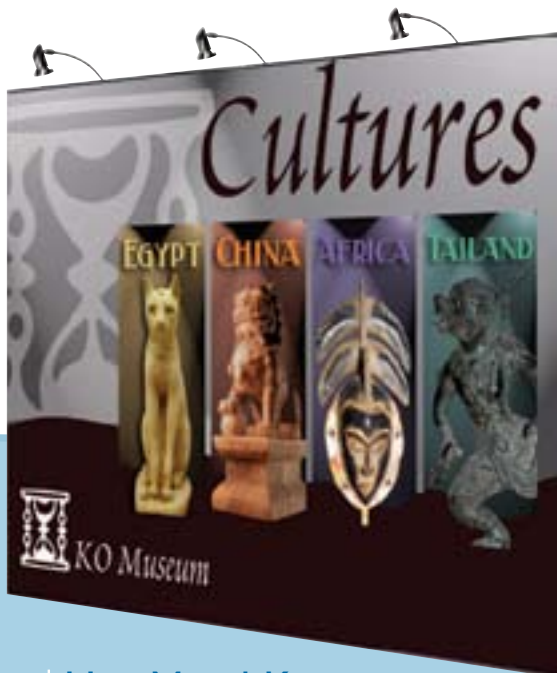

### Uno Mural Kit

- Stylish and practical
- Links 3 complete "Uno" or "Uno Plus" systems
- Packs conveniently into one hard molded case



### Metro

CB

- 24" wide double sided banner
- Telescopic pole design
- Modern urban style and function
- Silver finish

# Counters & Stands

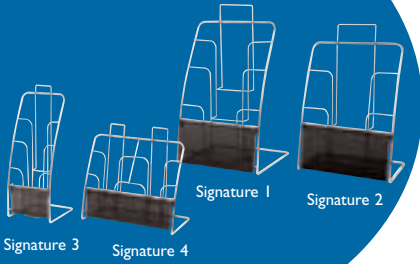

## Signature TABLE TOP RACKS

- 2 & 3 shelf designs
- Brochure & Envelope sizes
- Chrome finish with removable smoke plexi front panel

## Observe

PRO/LIGHT SIGNPOST

- Lightweight snap together design
- Holds a graphic up to 1/8" thick

Includes Pro:

- Stylish curved header
- Adjustable brochure holder



## Triangle COUNTER

- Create tiered display surfaces
- 32" X 32" X 32" scratch resistant black tops with EFEX bases
- 12", 24", 36" heights



## Square COUNTER

- Create tiered display surfaces
- 26" X 26" Scratch resistant black tops with EFEX bases
- 12", 24", 36" heights available



## Tornado OUTDOOR

- Outdoor promotion counter with storage area
- Molded base can be filled with water or sand
- Flexible plastic wrap makes it ideal in all weather



## Rectangle COUNTER

- Shown with "Illusion" collapsible literature rack
- 22" X 34" scratch resistant black top with EFEX base
- 35.5", 39.5" heights available



## Campaign

INDOOR or OUTDOOR

- Road-show & promotion counters
- Fast easy assembly
- Strong easy to clean
- Plastic construction
- Add an eye catching header



## Relay TRIPOD EASEL

- Lightweight
- Holds a standard size conference pad (not included)
- Sleek black finish
- Adjustable from floor model to tabletop display
- Maximum overall height 63"



## Trapezoid COUNTER

- 19.5" X 47" scratch resistant black top with EFEX base
- 35.5", 39.5" heights available

**CB** = Carry Bag included

# Literature Racks



## Zed-Up 1 COLLAPSIBLE

- 6-pocket, single width in silver
- Collapses and packs into hard case for transport

## Zed-Up 2 COLLAPSIBLE

- 6-pocket, double width in silver
- Collapses and packs into hard case for transport

## Zed-Up 1-B COLLAPSIBLE

- 6-pocket single width,
- Collapses and packs into carry bag and carton
- Available in black and silver

## Zed-Up Light COLLAPSIBLE

- Lightweight version of Zed-Up
- Aluminum frame with clear plexi dividers
- Comes complete with a hard carry case
- Available in silver finish

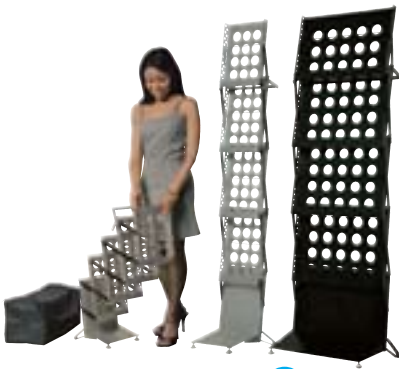

## Illusion COLLAPSIBLE

- Exceedingly versatile
- 4-pocket, Single or double widths available
- Cantilevers to compact portable size
- Textured black and silver finish



## Innovate MODULAR

- Stylish and practical
- 10-pocket
- Modular design
- Textured Black and Silver finish



## Reveal Pro COLLAPSIBLE

- Space saving roll up fabric pockets
- Reveal Pro 1
- Basic 4-pocket silver or black
- Reveal Pro 2
- Double 8 pocket in silver only



## Titan MODULAR

- Heavyduty double-sided
- 8-pocket ideal permanent or semi-permanent display
- Silver finish



## Victory MODULAR

- Slim-line attractive design
- 5-pocket
- Fast and easy assembly
- Textured silver finish



## Jazz MODULAR

- Unique pockets for portrait or landscape literature
- 3-pocket
- Black finish



## Slope FLAT PACK

- Elegant curved design
- 3-pocket
- Packs Flat for transport
- Silver finish



## 10-Up FLAT PACK

- Slim-line attractive design
- 10 chrome pockets
- Matte black finish
- Packs flat for transport

# Pop-Up *Displays*

2x2'  
Tabletop

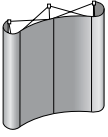

3x3'  
Exhibit

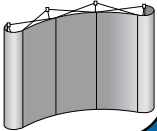

4x3'  
Exhibit

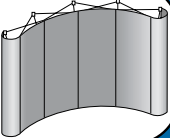

Gull-wing Exhibit

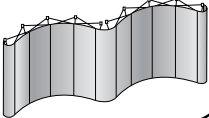

Serpentine Exhibit

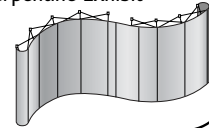

## Coyote POP-UP

- Perfect for large format graphic panels
- Many kits and additional designs available
- 7 new designer colours available in ribbed fabric at no extra charge



The **Coyote** popup display system combines strength and reliability with style and ease of use. Named "popup" because of its "small to large" pop-up action, this type of display system is still one of the most portable tradeshow and display solutions available.

The **Coyote** system **purple** frame features several unique advantages over other similar Popup display systems, especially its light weight and simplistic ease of use. Compared with complicated "snap in" channel bars and delicate locking/locating systems, the **Coyote** popup display system uses state of the art "**Rare Earth Neo Magnets**" on both its channel bars and locking/location systems. These make it very quick and simple to erect and take down, with practically no "easy to break" parts.

Full display systems are offered in a wide choice of configurations from basic tabletop kits to full 20' long displays. **Coyote** systems may be made with curved or also straight walls, single or double sided and offer the option of combining with either breath taking seamless graphic mural panels or versatile "Velcro friendly" fabric panels.



200 watt halogen available.



MADE  CANADA



## Ultima Plus POP-UP

- Perfect for large format graphic panels
- Many kits and additional designs available
- 7 new designer colours available in ribbed fabric at no extra charge

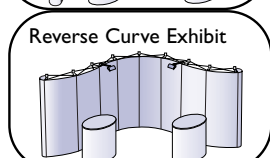
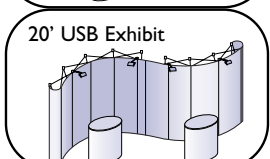
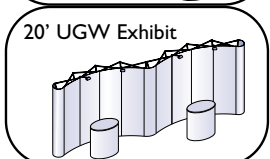
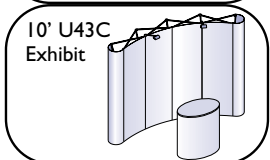
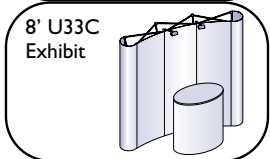
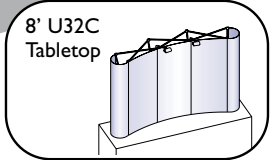
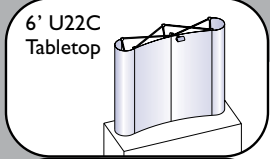
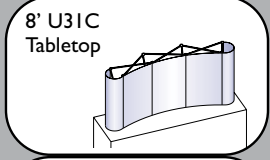
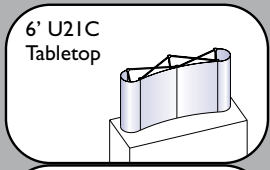

### Reliability

This pop-up frame is durably built to handle the wear and tear of any busy show schedule. It's all aluminum construction is lightweight and its 12" base makes it extremely stable.

### Simplicity

The frame pops up instantly, and the 3 in 1 folding channel bars \* allow for quick tool-free set-up ... just add lights and panels and it's ready to go.

### Portability

The 10' U43C packs into a single case - including panels, frame, lights, channel bars, and case to counter kit.

### Affordability

Ultima Plus is simply the best value and the highest quality pop-up in the industry. Optional fabric panels, 200W Halogen spotlights and Case-to-Counter conversion kit complete the perfect portable display.

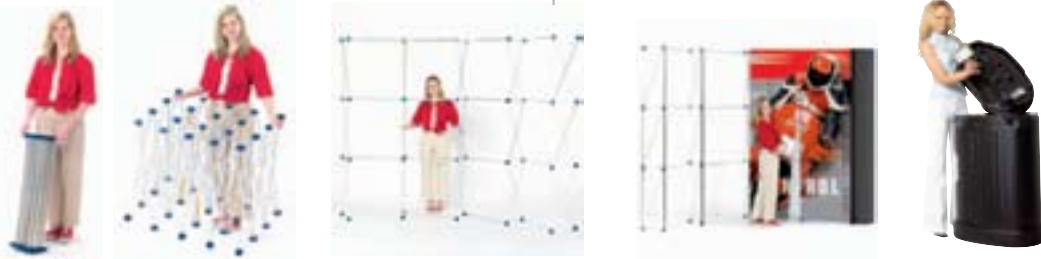

### Efficiency

Set-up in seconds and packed away just as fast. This pop-up system is fast and efficient with a durable yet lightweight aluminum construction.

### Convenience

The durable fabric graphic system stays attached to the aluminum frame for storage and transportation.



## Hop-Up

- Graphics stay on the frame for speedy set up
- Packs away into a single portable case
- Hard case or soft case are available accessories

\* Applies to free standing units only.

# Panel Systems

MADE  CANADA

## EFEX FOLDING PANEL SYSTEMS

This lightweight design has the ability to fold, making this the ideal choice for an exhibitor seeking flexibility to meet changing needs. These modular displays can be used as table-top displays or combined together to create floor displays in minutes without the need for tools. The addition of a header and lights to EFEX will create the perfect vehicle to promote your message while allowing for reconfiguration of the display for changing venues. Velcro® compatible fabric finish allows for full customization with a wide range of graphics. Add an EFEX display counter for a polished professional look.

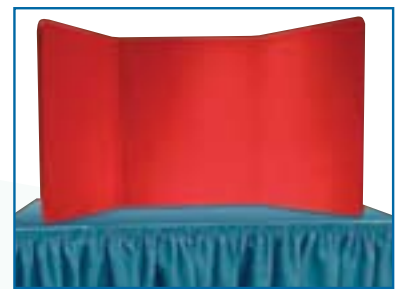
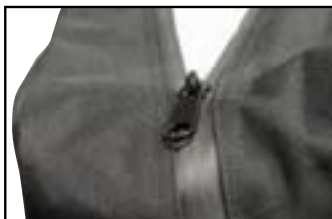

Tabletop models available.



Replacement Bulb Pack available

### EFEX Carry Bag

- Stylish black carrying bag
- Water resistant rubber zippered opening
- Transparent card pocket.
- With shoulder straps, & carry handle

### EFEX Light

This lightweight slip on light, adds dramatic impact on all EFEX displays. 50 watt MR16 Halogen bulb.

# EFEK Models

## Accessories

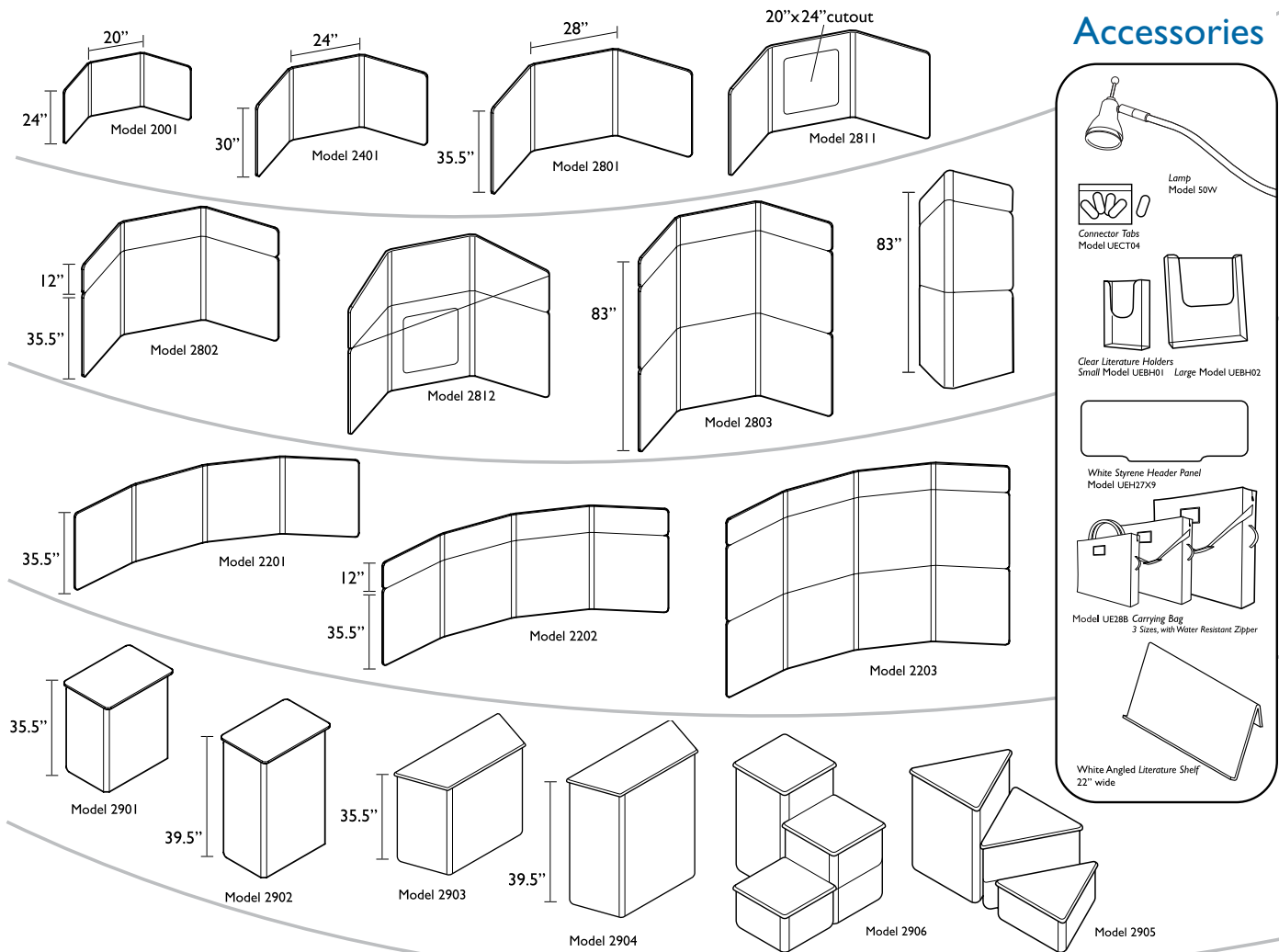

## Voyager BRIEFCASE PANEL SYSTEM

The Voyager panel systems offer a Briefcase style, tabletop presentation solution. This highly portable display is available in two sizes offering a hard molded outer skin and a Velcro® compatible fabric inner. Add graphics for a dazzling tabletop display! Standard system has black plastic outer skin and black fabric inner.



Voyager offers the option of having the inner fabric finish or the hard molded outer skin in your choice of custom colour (minimum order of 100 kits required for this option)

# Orbital Extreme Truss *Displays*

Orbital Truss is the latest in stylish, eye catching, dynamic trade show structures. Kits are quick and easy to assemble and are available in all sizes including 10' X 10', 10' X 20' and 20' X 20' Island (as shown below). All orbital truss booth designs are available with attractive chrome spotlights and adjustable counter tops.

Between straight and curved truss components the only limitation to any design is one's imagination.

Mercury 10x10



Pluto 10x10

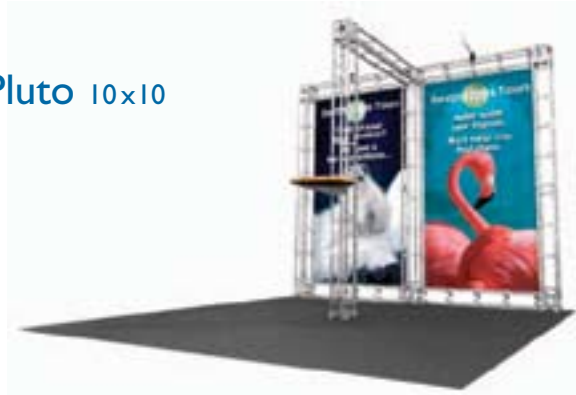

Venus 10x20



Polaris 10x20



Orion 20x20



Centaurus 20x20



Quick & Easy ASSEMBLY



Complete

with chrome spotlights and adjustable countertops

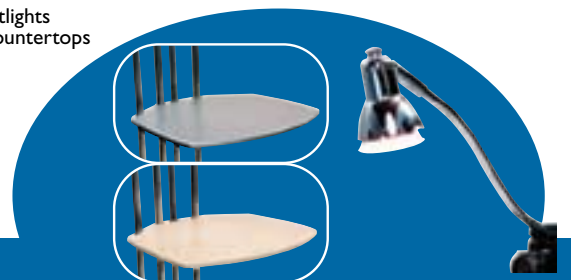

# Motorized & Outdoor

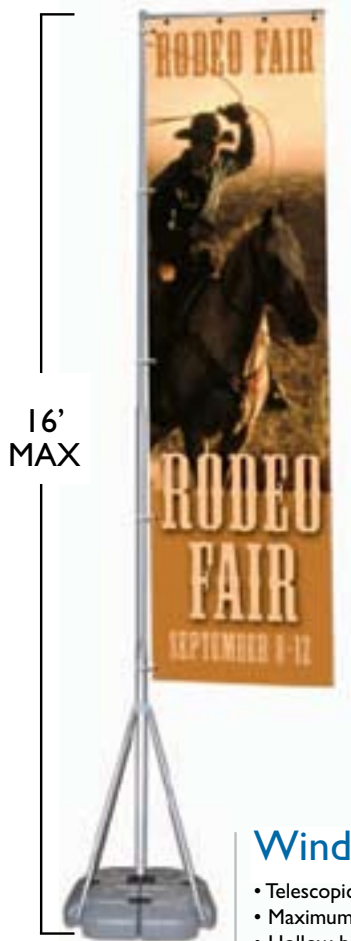

## Wind Dancer OUTDOOR FLAGPOLE

- Telescopic pole
- Maximum display height of up to 16'
- Hollow base can be filled with sand or water



## Maverick Standard MOTORIZED

- Constant rotating image
- Floor stand base designed for stability



## Maverick MOTORIZED

- Constant rotating image
- Floor stand base designed for stability



## Revolution MOTORIZED

- Motorized scrolling, rotating banner display
- Can be mounted to a wall or ceiling surface

## Storm OUTDOOR

- Hollow base can be filled with sand or water
- 24.5" w vinyl graphics with eyelet or grommet are easily attached
- Very stable outdoor presentation
- Single or double sided



## Storm Pro OUTDOOR

- 24" wide outdoor banner stand
- Smaller more portable base
- Banner graphics are easily attached
- Telescopic support pole and completely adjustable central hub allow you to vary the height and width of the graphic



# Graphic P-O-P *Displays*

The wide range of Point-of-Purchase display systems offer simple assembly, changeable graphics and the impact in allowing the message to stand out. Add internal lights on some units and create an even greater "Wow" factor.

The "Quick Switch" system allows graphic panels to slide in and out by simply removing a single extrusion and replacing it fast and efficiently. All units are constructed with a rugged aluminum extrusion. Redesigned bases are new black scratch resistant krinkle coat. Silver bases available by quote.



**UF2** P-O-P DISPLAY



**UE2** P-O-P DISPLAY



**UE1** P-O-P DISPLAY



**UF1** P-O-P DISPLAY



**UST** P-O-P DISPLAY

## Quick Switch

GRAPHIC SYSTEM



**UE1**



**UE2**



**UF1**



**UF2**



**UST**



**UTT**



## Double Wedge SIGN STAND

- Use two bases to hold much larger signs!
- Multiple uses
- Can be used with double sided graphics



## Wedge SIGN STAND

- Simple, cost effective rigid banner for indoor or outdoor use
- Suitable to support a variety of woods, acrylic and other rigid substrates up to 40 mm thick
- Stable 12" or 24" wide steel base

# Cases & Lighting

Make the most out of your investment in a display system or high quality graphic and transport your exhibit in a molded case. A variety of models are available to suit all your needs.

Add impact to a banner stand or display system by simply illuminating them with the attractive Lumina line of spotlights.



## Graphics & Accessory

SHIPPING CASE

- Durable construction
- Inside diameter of 14"
- Ideal for rolled graphics & accessories
- Easy to wheel around



Heavy-duty hardware is standard on all cases !



## Pop-Up & General Use UPWC

- State of the art blow molding technology
- Strong yet light construction
- Reliable built in wheels and handle
- Internal storage in lid for standard lights or accessories
- Can easily be converted into a counter or podium



## Orbital UFC 1

- Large general purpose Freight case
- Forklift truck friendly shape
- Built in castor wheels for easy movement even without a truck



## Orbital UFC 2

- Round Freight case
- Perfect for curved orbital displays

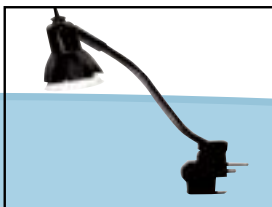

## Lumina 1

- 50 watt halogen light
- Black finish
- Stylish and practical
- Ideal for EFX panel system

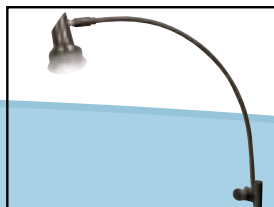

## Lumina 2

- 35 watt halogen light
- Silver finish
- Stylish and practical
- Ideal for banner stands
- Accepts 50 watt replacement bulbs



## Custom Carry Bags

- Choose from a range of standard carry bags or have a custom size made
- Minimum order needed
- Inquire for details



## Stretch Pak

PROJECTION SCREEN

- Table top projection screen
- Lightweight, easy to use
- Extends up to 50" diagonal screen size.
- Retracts to sturdy aluminum case for transport
- Black finish



## 2 Bulb Replacement Pack

- Available in 35 watt or 50 watt
- Zippered clam shell protective case

## **CONVINCE GRAPHICS**

77 Water Street, Suite B  
Campbellton, NB E3N 1A9

**(p)** 506.789.7765

**(f)** 506.789.6669

[info@convincegraphics.com](mailto:info@convincegraphics.com)

**[www.convincegraphics.com](http://www.convincegraphics.com)**